



THE ALL-NEW MACK® MD SERIES

BUILT FOR GROWTH.



MACK MD6 LOW PROFILE

Dependability, durability and steadfast support—everything you’ve come to expect from Mack is now available in a medium-duty truck. We’re proud to introduce the Mack MD Series. These trucks are packed from the exterior to the driver environment with features to ensure a smooth, stress-free ride—backed by our unmatched local dealer support. The Mack MD6 Low Profile is designed for ease of street loading and vocations that require lower chassis height, such as towing and recovery.

Dock height model shown.

BORN READY.

MACK® MD6 LOW PROFILE

KEY FEATURES

Cab air suspension (standard)

Full-width aluminum grated steps for easy entry and egress, horizontally offset for visibility (standard)

50-gallon fuel tank (standard), 90-gallon (optional)

Frame rails rated at 120,000 psi yield strength (standard)

34-in. assembled frame width

Rear leaf spring suspension (standard), Mack Air Ride (optional)*

*Mack MaxiLite Air Ride available on select wheelbases only.

Tires 255/70R 22.5-inch Low Profile tires on MD6 Low Profile version

Steel powder coat disc wheels (standard), aluminum wheels (optional)

Passenger door lower peep window (standard)

Flat back-of-cab and clear frame platform for easy body installation

Wheelbases to accommodate 10- to 26-foot typical van bodies

Clear space on driver and passenger side frame rails



Comfortable Interiors

The Mack MD6 Low Profile brings heavy-duty levels of driver comfort and functionality to medium-duty trucks, to keep drivers comfortable and safe all day. Tilt/telescoping steering column, air suspension driver seat and all controls within reach keep drivers in control.

All Day Uptime

Mack uses Geotab® to integrate the MD6 Low Profile into our industry-leading Uptime Services. Mack's ASIST platform streamlines and shares all service communications among the customer, dealer and Mack's 24/7 Uptime Center.

Typical Dry Van Body Length	(ft.)	10	12/14	16	18	20	22	24	26
Wheelbase*	WB (in.)	150	166	186	206	221	236	251	270
Cab to Rear Axle	CA (in.)	87	103	123	143	158	173	188	207
After Frame	AF (in.)	50	55	60	65	70	80	90	100
Overall Length Chassis	OL (in.)	240	261	286	311	341	366	391	410
GVWR	(lb.)	25,995	25,995	25,995	25,995	25,995	25,995	25,995	25,995
Front Axle Capacity	(lb.)	10,000	10,000	10,000	10,000	10,000	10,000	10,000	10,000
Rear Axle Capacity	(lb.)	17,000	17,000	17,000	17,000	17,000	17,000	17,000	17,000
Front Axle Weight	(lb.)	5,930	6,060	6,100	6,165	6,195	6,245	6,290	6,320
Rear Axle Weight	(lb.)	3,310	3,245	3,270	3,290	3,335	3,375	3,410	3,460
Total Chassis Weight**	(lb.)	9,240	9,305	9,370	9,455	9,530	9,620	9,700	9,780

*Wheelbase selection should be based on specific weight distribution.

**Total Chassis Weight is for standard specifications EXCLUDING driver and fuel.

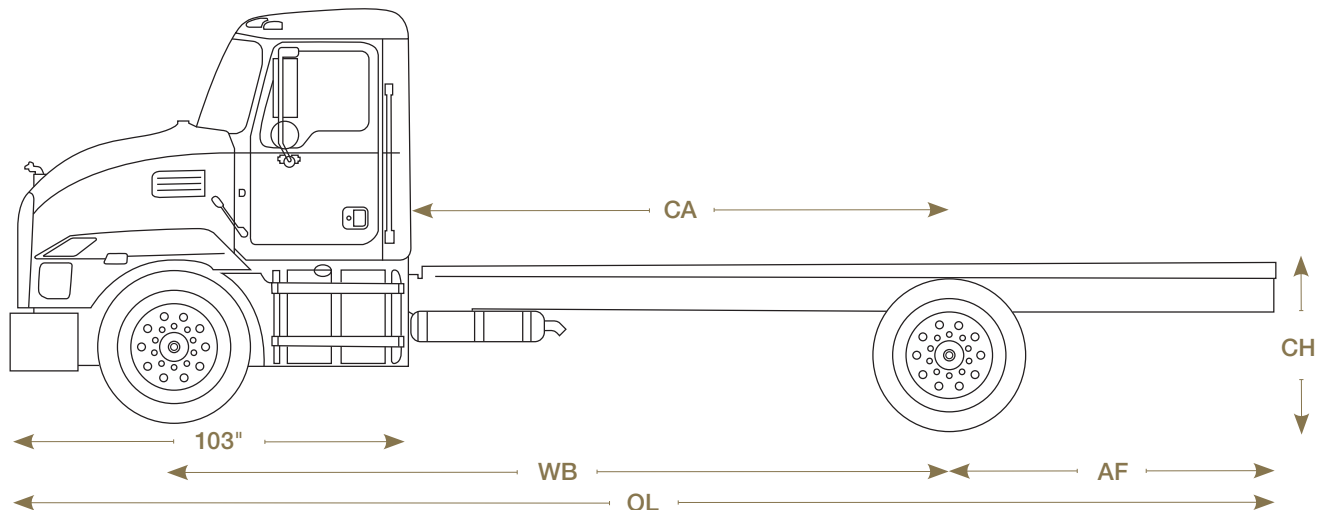

MACK® MD6 LOW PROFILE

ENGINE	Cummins® B6.7 Inline 6-cylinder, Turbo/Intercooled Diesel
Horsepower/Torque	220 hp/600 lb. ft.
	240 hp/560 lb. ft.
	250 hp/660 lb. ft.
	260 hp/660 lb. ft.
	280 hp/660 lb. ft.
300 hp/660 lb. ft.	
Air Cleaner Type	11 in.
Alternator	Delco 12V, 145 amp
Batteries	Dual 760CCA (1520 total CCA)
Engine Brake	Cummins, with dash switch
Fuel Filter	Filter and Water Separator
	Heated, Fuel and Water Separator
Starter	Melco12V

TRANSMISSION	STANDARD Allison 2500HS 6-speed, double OD rated to 660 lb. ft. torque, w/Fuel Sense 2.0 Plus	OPTIONAL Allison 2500RDS 6-speed, double OD rated to 660 lb. ft. torque, w/Fuel Sense 2.0 Plus

REAR AXLE RATIOS

RA Ratio	5.29	5.57	4.88*	5.29	5.57	4.88*
Est Engine RPM @ 65 mph	2150	2264	1984	2150	2264	1984

*4.88 R/A ratio not available with MS-17-13x or 14x rear axle.

FRONT AXLE

GAWR	10,000 lbs.
Axle Type	Meritor MFS-10, I-Beam
Suspension	Hendrickson Taper Leaf, 10,000 lbs.
Shock Absorbers	Telescopic type

CHASSIS FRAME

Rail Dimensions	260 x 70 x 7 mm
Yield Strength and RBM	120k psi, 1,373m RBM
Assembled Width	34 in. (864 mm)

REAR AXLE	STANDARD	OPTIONAL	OPTIONAL	OPTIONAL
GAWR (lb.)	17,000	17,000	19,000	19,000
Axle Type – Meritor	MS-17-13x	MS-17-14x*	MS-19-13x*	MS-19-14x*
Suspension – Taper Leaf (lb.)	19,000			
Suspension – Optional (lb.)	Mack AL 190 19,000**			

□ Shaded areas indicate optional equipment.

*14x and driver controlled differential lock, Rear axle option equipped with driver controlled differential lock.

**Rear air suspension available on 206, 221, 236, 251 and 270 in. wheelbases only.

CAB	Steel cab with Premium trim level
Air Conditioning	Standard
Audio	AM/FM with Bluetooth
Cab Lighting	Interior courtesy lights (2)
Cab Mirrors	Bright finish with lower convex mirror
Cab Suspension	Dual airbag cab suspension
Cruise Control	Standard
Cup Holders	Two large cup holders in console
Passenger Door Window	Lower door window with lens
Power Outlets	12 volt and USB
Power Steering	Standard
Power Windows and Locks	Standard
Pro Dash	Premium dash cluster
Seat Driver	High back, air suspension w/vinyl
Seat Passenger	High back, fixed base w/vinyl
Steering Column	Tilt and Telescopic
Steering Wheel	Flat-bottom steering wheel
Sun Visors	Driver and Passenger

BRAKE SYSTEM

	Bendix® Antilock Braking System S Cam Air Brake System
Front Brakes	Meritor® S Cam Q+, 16.5 x 5 in.
Rear Brakes	Meritor S Cam Q+, 16.5 x 7 in.
Parking Brake	Rear axle, spring brake

FUEL TANK

Round 22 in., driver side, 50 gallons

Round 22 in., driver side, 90 gallons

DEF TANK

25 liter, passenger-side

WHEELS

Accuride steel disc, powder coated white wheels
8.25 x 22.5 in., offset 6.6 in., 5-hole

Accuride aluminum wheels
8.25 x 22.5 in., offset 6.59 in., 10-hole

TIRES

Bridgestone R250 ED radial
All season, all positions, 255/70R 22.5 in. (H)

Bridgestone M726 radials
Traction, rear position, 255/70R 22.5 in. (H)

MACK® MD6 LOW PROFILE



Dock height model shown.

WARRANTY SUMMARY	MD Series Models MD6, MD7
Typical Vocations	Distribution, Short Haul or P&D
Axle Configuration	4 x 2
Basic Coverage	24 months/unlimited miles*
Batteries	12 months/unlimited miles
Chassis Towing	90 days or 5,000 miles (8,047 KM), whichever occurs first*
Air Conditioning	24 months/unlimited miles – air conditioning (sealed system only)
Engine/Emission	Warranty coverage provided by Cummins® Engine
Transmission	Warranty coverage provided by Allison Transmission®
Driveline, Rear Axle, Front Steer Axle	24 months/unlimited miles*
Cab Structure and Internal Cab Corrosion	60 months/unlimited miles*
Frame Rail / Cross Members	60 months/unlimited miles*
Noise Emission	Life of vehicle*

*See complete warranty certificate for details.

Shaded areas indicate optional equipment.

All illustrations, specifications and descriptions in this specification are based on the latest product information available at the time of this publication. The right is reserved to make changes in price, materials, equipment, design, specifications, diagrams and models, and to discontinue models of equipment at any time, without notice and without incurring any obligation whatsoever. For more information on additional options and accessories, contact Mack Trucks, Inc. (www.macktrucks.com).

UPTIME SUMMARY	MD Series Models MD6, MD7
Mack OneCall®	12 months
Mack ASIST	12 months
Geotab® Basic	12 months
PURCHASE OPTIONS	
Mack OneCall	24-60 months, in 12 mo. increments
Mack ASIST	24-60 months, in 12 mo. increments
Geotab Basic	24-60 months, in 12 mo. increments
Geotab Plus	12-60 months, in 12 mo. increments

OTHER OPTIONS	
Allison Programming	Fuel Sense 2.0 MAX
Battery Shut Off	Under cab, passenger side
Engine Block Heater	
Air Filter Indicator	Under hood, restriction indicator mounted to air cleaner
PTO Preparation Kit	Harness and switch kit
Cab Mirrors	Chrome finish with convex mirror, heated and motorized
Seat Passenger	Two-person bench seat w/vinyl and under seat storage
Drivers Seat Trim	Modura cloth upgrade seat upholstery
Passenger Seat Trim	Modura cloth upgrade seat upholstery
Passenger Bench Trim	Modura cloth upgrade seat upholstery

